

## Coil Upenders/Downenders Jarret Shock Absorber Application

### Application Overview

Coils of finished strip are often required to be re-positioned in such a way that the coil access changes from being horizontal to vertical or visa-versa. The repositioning mechanism is frequently in the form of a direct drive geared system. Hydraulic cylinders, the speed of which are controlled by hydraulic control valves and hydraulic deceleration devices, may also be used.

### Problem

Safety limit switches are used to limit the travel range of the upender/downender or, in the case of a hydraulic system, control valves are used. If these switches or valves are incorrectly adjusted or malfunction, the coil can be slammed down on to the receiving table or conveyor, subjecting it to not only the momentum of the moving tilter and coil, but also to the force of the drive system.

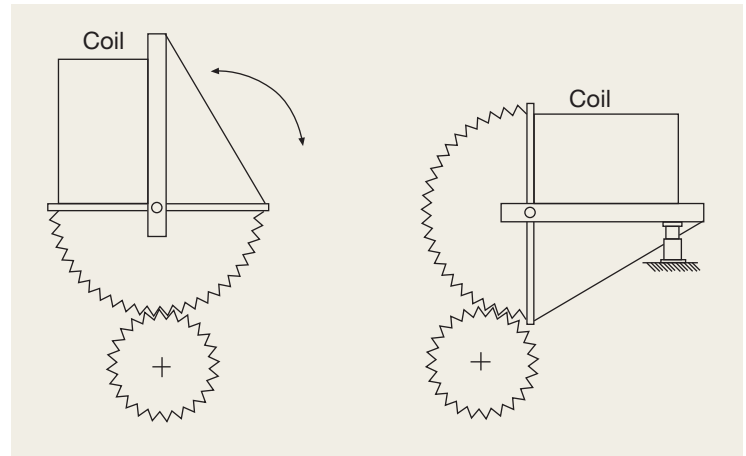

### Product Solution

Jarret shock absorbers are ideal for this application because they provide full energy absorbing capability at the low operating speeds common with this type of equipment. Since the reaction of a Jarret shock absorber increases with stroke, they will not bottom out when the tilter is driven into them. As they are stroked, the reaction increases to overbalance the drive force with enough remaining capacity to remove the kinetic energy, thereby assuring a gradual, shock-free stop, without reaching the end of the stroke, ie. bottoming out.

The installation of a relatively inexpensive Jarret elastomeric shock absorber can therefore prevent damage to both the coil surface and the receiving mechanism.

An inventory of standard sizes provides ready availability for most applications. Factory repair is available to recondition worn units if required, thus assuring long economical service.